

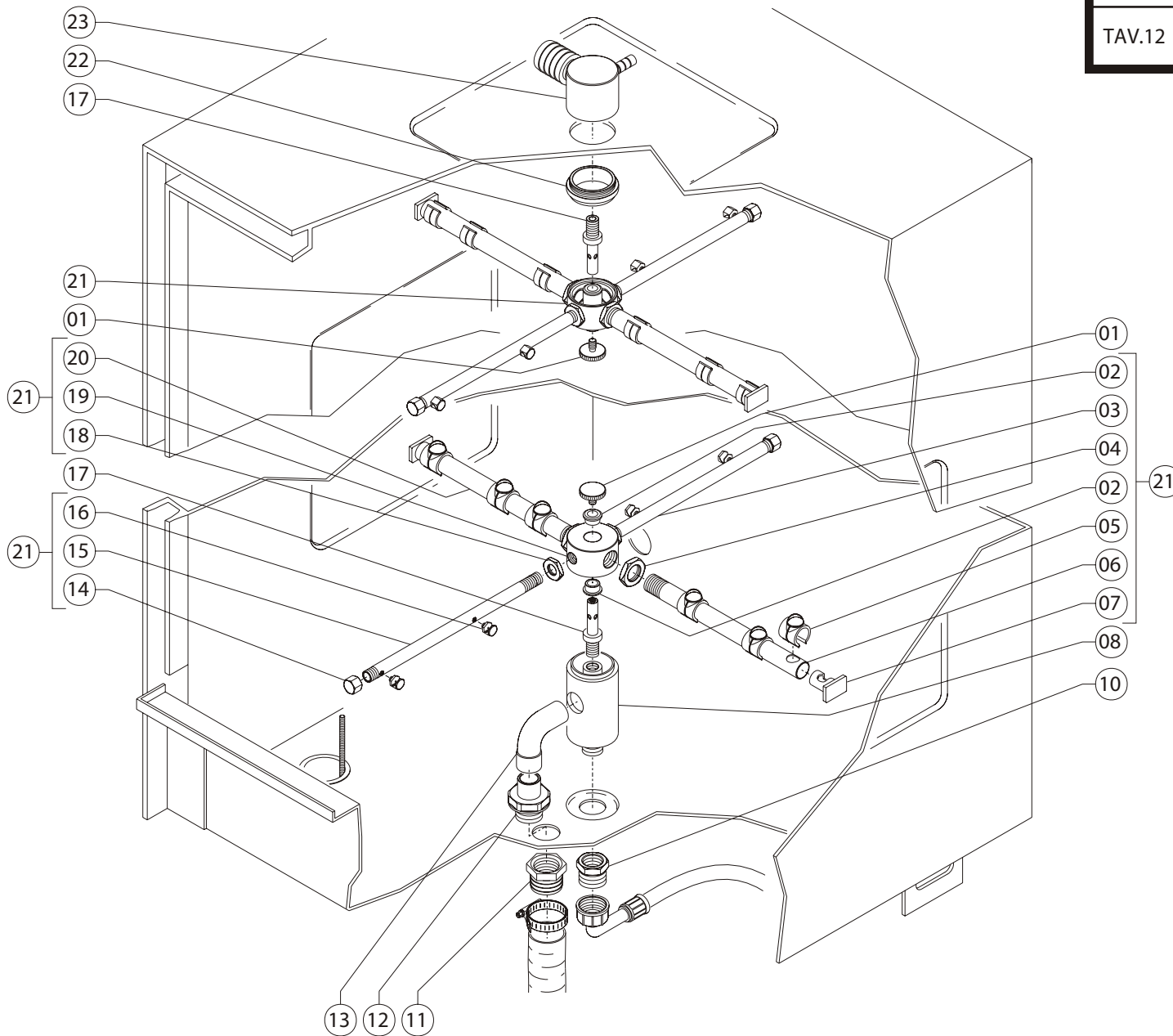

POS.	CODICE MODELLO:			DESCRIZIONE	DESCRIPTION	DESCRIPTION	BESCHREIBUNG	Q.TY
	210	500	-					
1	5010	5010		Optional motore pompa scarico 190W	Opt.discharge pump motor,190W	Option moteur pompe vidange 190 W	Opt. Motor für Pumpe vom Abfluß 190W	1
2	1315	1315		Tubo di scarico 25 mm ø	Discharge pipe, ø25 mm	Tuyau de vidange ø25 mm	Abflußschlauch ø25 mm	1
3	210705	500705		Manicotto ø32 mm raccordo inf.	Lower joint hose,rubber ø32 mm	Manchon 32 raccord inf.ø	Muffe ø32 mm unterer Anschluß	1
4	500	500		Fascetta inox 10-20	Stainless steel band, 10-20	Collier inox 10-20	Schelle aus Edelstahl 10-20	6
5	1215	1215		Peso per tubetto aspirazione	Weight for intake tube	Poids pour petit tuyau aspiration	Gewicht für Ansaugschlauch	1
6	1218	1218		Filtro per tubetto aspirazione	Filter for intake tube	Filtre pour petit tuyau aspiration	Filter für Ansaugschlauch	1
7	210720	500720		Tubo lavaggio sup. ø30 mm	Upper rinse pipe, ø30 mm	Tuyau rinçage sup. Ø30 mm	Lausc oberes Nachp len ø30mmü	1
8	210750	210750		Raccordo a T inox 32 mm ø	Stainless steel T-joint, 32 mmø	Raccord en Té inox 32 mmø	T-Anschluß aus Edelstahl 32 mmø	1
9	210420	500420		Boiler inox	Stainless steel boiler	Chauffe-eau inox	Boiler aus Edelstahl	1
10	520	520		Fascetta inox 21-44	Stainless steel band, 21-44	Collier inox 21-44	Schelle aus Edelstahl 21-44	5
11	210705	500705		Manicotto ø32 mm raccordo inf.	Lower joint rubber hose, ø32 mm	Manchon ø 32 raccord inf.	Muffe ø32 mm unterer Anschluß	1
12	103410			Resistenza boiler 2000 W	Tank heater, 2000W	Résistance cuve 2000 W	Heizschlange Becken 2000 W	1
12		103425		Resistenza boiler 3300 W	Tank heater, 3300W	Résistance cuve 3300 W	Heizschlange Becken 3300 W	1
13	103415	103415		Guarniz. or per resistenza con flangia	OR heater gasket with flange	Bague torique résistance avec bride	O-Ring-Dichtung Heizsch. mit Flansch	1
14	1210	1210		Dosatore di detergente elett. regolabile	Adjustable electric detergent doser	Doseur détergent électrique réglable	Elektr., einstellb. Dosierer für Spülmittel	1
15	1212	1212		Tubetto in santoprene	Santoprene tube	Petit tuyau en santoprène	Kleiner Schlauch aus Santopren	1
16	1200	1200		Dosatore di brillantante	Rinse doser	Doseur de liquide rinçage	Dosierer für Klarspüler	1
17	1380	1380		Tubo di gomma 10-19 90°C al mt	Rubber hose, 10-19 90°C per metre	Tuyau en caoutch. 10-19 90°C au mètre	Gummischl. 10-19 90°C, profd. M	1
18	103370	103370		Elettrovalvola	Solenoid valve	Electrovanne	Elektroventil	1
19	1305	1305		Tubo carico acqua da 2.0 mt	Water entry pipe, 2.0 m	Tuyau de remplissage eau de 2.0 m	Wasseransaugschlauch,2 .0m lang	1
20	217000	500700		Manicotto ingresso pompa	Pump entry rubber hose	Manchon entrée pompe	Muffe Pumpeneingang	2
21	530	530		Fascetta inox 40-65	Stainless steel band, 40-65	Collier inox 40-65	Schelle aus Edelstahl 40-65	1
22	6200			Motore pompa lavaggio Hp 0,7	Wash pump motor, 0.7 HP	Moteur pompe lavage HP 0,7	Motor Spülpumpe 0,7 PS	1
22		6300		Motore pompa lavaggio Hp 0,7	Wash pump motor, 0.7 HP	Moteur pompe lavage HP 0,7	Motor Spülpumpe 0,7 PS	1
23	6210	6310		Chiocciola motore pompa	Pump motor volute	Vis sans fin moteur pompe	Spiralgehäuse Pumpe motor	1
24	6211	6311		Girante motore pompa	Pump rotor	Roue pompe	Lauftrad Pumpe	1
25	6014	6014		Guarnizione tenuta rotante	Rotary sealing gasket	Joint d'étanchéité rotatif	Dichtung Lauftrad	1
26	6013	6013		Guarnizione tenuta ceramica	Ceramic sealing gasket	Joint d'étanchéité céramique	Keramikdichtung	1
27	6212	6312		Guarnizione or per chiocciola pompa	Pump volute OR gasket	Bague torique pour vis sans fin pompe	O-ring-dichtung für Spiralgehäuse Pumpe	1
28	6215	6315		Condensatore motore	Motor capacitor	Condensateur moteur	Kondensator vom Motor	1
29	103400	-		Resistenza vasca 2000 W	Tank heater, 2000W	Résistance cuve 2000 W	Heizschlange Becken 2000 W	1
29	-	103407		Resistenza vasca 3000 W	Tank heater, 3000W	Résistance cuve 3000 W	Heizschlange Becken 3000 W	1
30	1130	1130		Gomito raccordo in plastica da 1"	Plastic elbow joint,1"	Coude raccord en plastique de 1"	Kniestück Plastikanschluß 1" Zoll	1
31	1131	1131		Guarnizione piana scarico 1"	Discharge gasket 1"	Bague vidange 1"	Dichtung Abfluß 1"	1
32	1410	1410		Tubetto 6x4mm trasparente	Transparent tube, 6x4 mm	Petit tuyau 6x4 mm transparent	Kleiner transpar. Schlauch 6x4 mm	1
33	1211	1211		Raccordo completo iniettore vasca	Complete joint for tank injector	Raccord complet injecteur cuve	Kompletter Anschluß Becken	1
34	210725	500725		Tubo di gomma 90°c per racc. da3/4G	90°C rubber tube with joint, 3/4G	Tuyau en caoutch. 90°C avec raccord de3/4G	Gummisch. 90° mit Anschluß 3/4G Zoll	1
35	1132	1132		Rosetta ottone 1"	Joint nut,1"	Ecrou raccord 1"	Mutterschraube für Anschluß 1" Zoll	1
36	1123	1123		Tubo troppo pieno 25 mm ø	"Too full" pipe, ø25 mm	Tuyau trop-plein ø25 mm	Überlaufschlauch ø25 mm	1
37	3250	3250		Filtro inox	Stainless steel filter	Filtre inox	Filter für Edelstahl	1
38	3280	3280		Trappola d'aria	Air trap	Prise d'air	Luftfalle	1
39	6213	-		Flangia motore pompa HP 0,7	flange wash pump 0,7 HP	Bride moteur pompe	Flansch Pumpenmotor	1
39	-	6313		Flangia motore pompa HP 0,7	flange wash pump 0,7 HP	Bride moteur pompe	Flansch Pumpenmotor	1

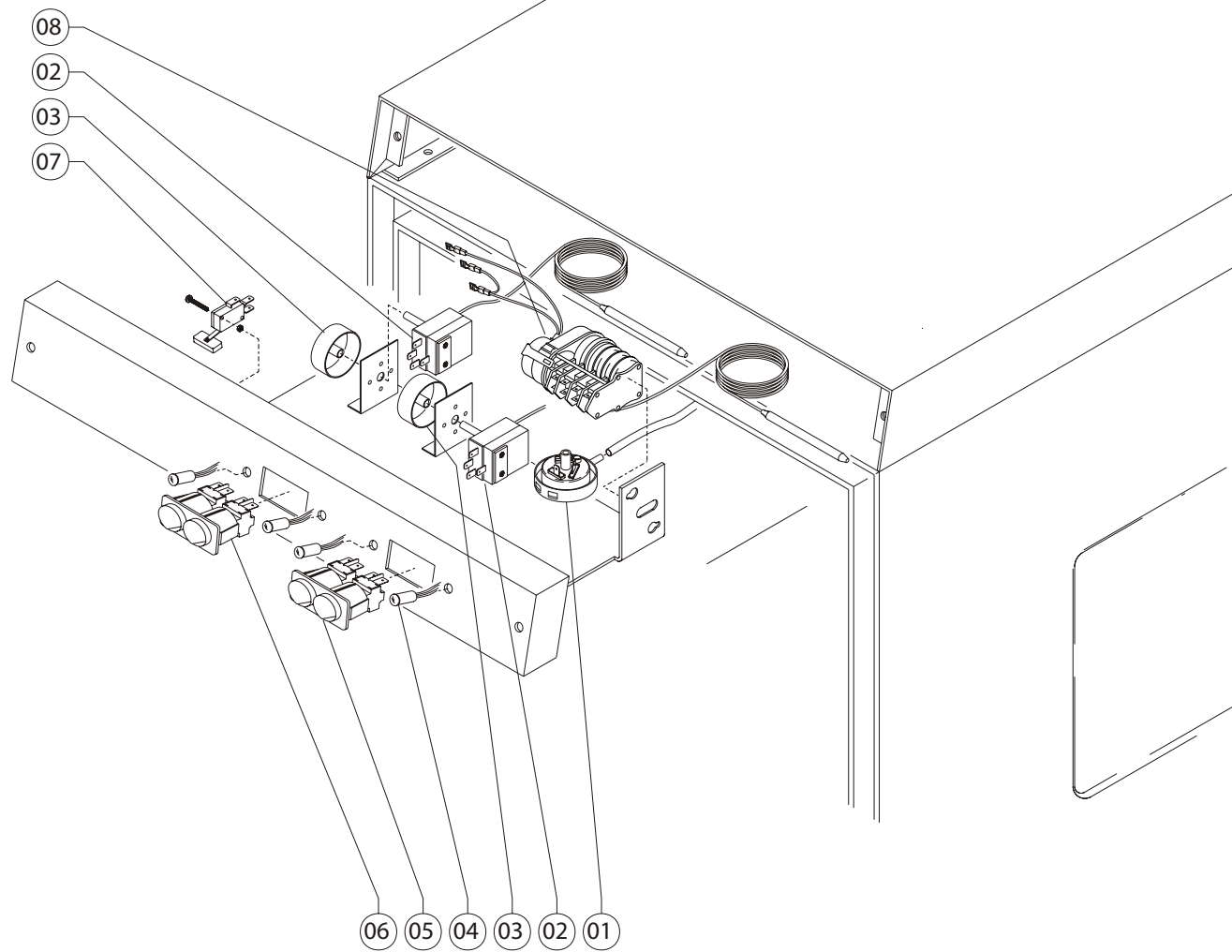

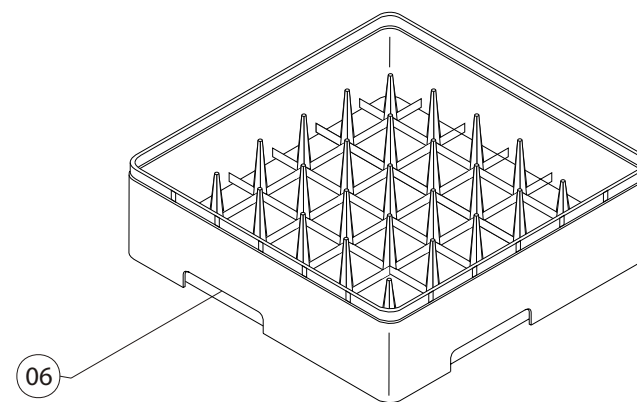

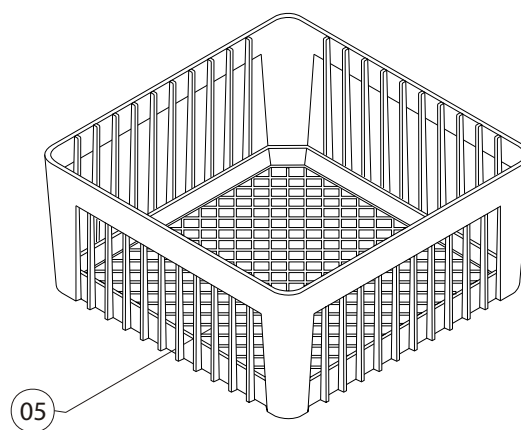
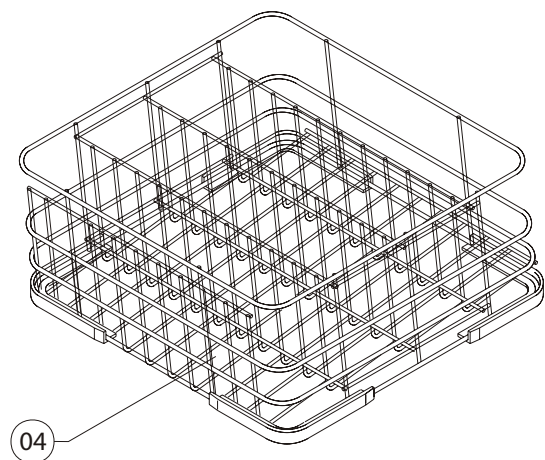
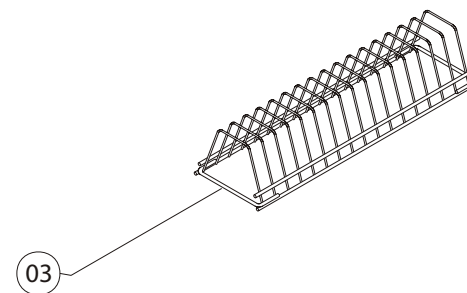
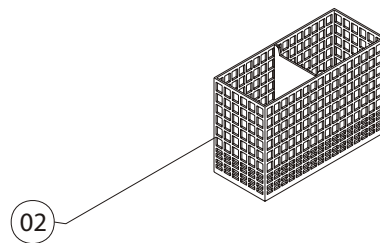
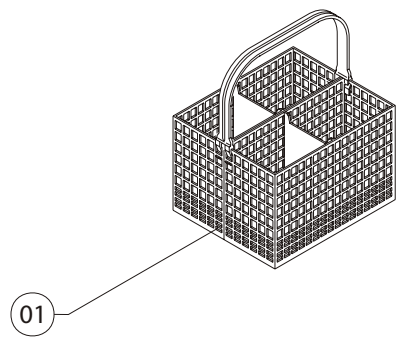

KORAL 500

TAV.16

CESTELLI

